

Centre Number	Candidate Number	Name
---------------	------------------	------

UNIVERSITY OF CAMBRIDGE INTERNATIONAL EXAMINATIONS  
International General Certificate of Secondary Education

**BIOLOGY**

**0610/05**

Paper 5 Practical Test

May/June 2006

**1 hour**

Candidates answer on the Question Paper.  
Additional Materials: As listed in Instructions to Supervisors.

**READ THESE INSTRUCTIONS FIRST**

Write your Centre number, candidate number and name on all the work you hand in.  
Write in dark blue or black pen.  
You may use a pencil for any diagrams or graphs.  
Do not use staples, paper clips, highlighters, glue or correction fluid.

Answer **both** questions.

At the end of the examination, fasten all your work securely together.  
The number of marks is given in brackets [ ] at the end of each question or part question.

For Examiner's Use	
1	
2	
<b>Total</b>	

This document consists of **7** printed pages and **1** blank page.



Answer **both** questions.

Write your answers in the spaces provided.

- 1 In this question you are to investigate the energy content of food substances.

Fig. 1.1 shows the apparatus you will use.

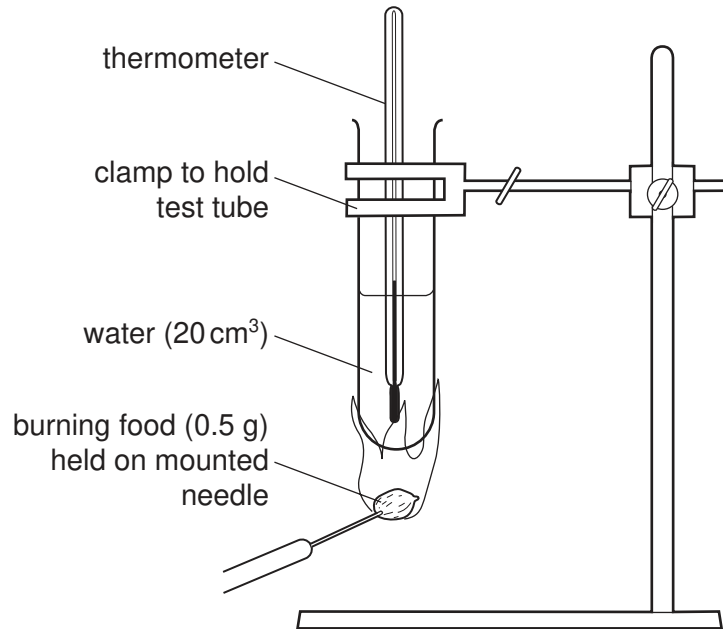

Fig. 1.1

- Measure 20 cm<sup>3</sup> of water and pour into the test tube.
  - Clamp the test tube in the stand as shown in Fig. 1.1.
- (a) (i) Draw a table in which information about the **mass** of the food **S1**, **volume** of water, its **initial** and **final temperatures** and **rise in temperature** will be recorded.

[3]

- Measure and record the temperature of the water. ....
- **Carefully** stick the mounted needle into the food **S1**.
- Hold the food in a flame until it starts to burn.
- Move the food so that it is burning under the test tube (see Fig. 1.1).
- Keep the food under the test tube until the flame goes out.
- Try to relight the food and move it under the test tube again.
- Repeat until it will no longer relight.
- Carefully put the mounted needle down on the heatproof mat.
- **Immediately**, measure and record the temperature of the water. ....

(ii) Complete the table. [3]

The energy contained in the food **S1** can be calculated using the formula below.

$$\text{Energy} = \frac{\text{volume of water} \cdot \text{rise in temperature} \cdot 4.2}{\text{mass of food S1}}$$

(iii) Use the formula to calculate the energy content (in joules per gram) of the food **S1**.

Show your working.

$$\text{Energy content} = \dots\dots\dots \text{J g}^{-1} \quad [3]$$

(iv) Convert your answer into kilojoules per gram.

$$\text{Energy content} = \dots\dots\dots \text{kJ g}^{-1} \quad [1]$$

(b) This is not a very accurate way of finding out the energy value of a piece of food.

(i) Suggest **two** reasons why the result may not be accurate.

1 .....

.....

2 .....

..... [2]

(ii) Suggest how the method could be improved to increase the accuracy and reliability.

.....

.....

.....

.....

.....

..... [2]

(c) Table 1.1 shows the results of similar experiments using 1g samples of different substances.

Table 1.1

substance	energy content /kJ
carbohydrate	5
fat	10
protein	2
food <b>S1</b>	

(i) Complete the table to show the energy content, in kJ, of 1g of food **S1**. [1]

- (ii) On the grid below, plot a suitable graph to compare the energy content per gram of the four different substances.

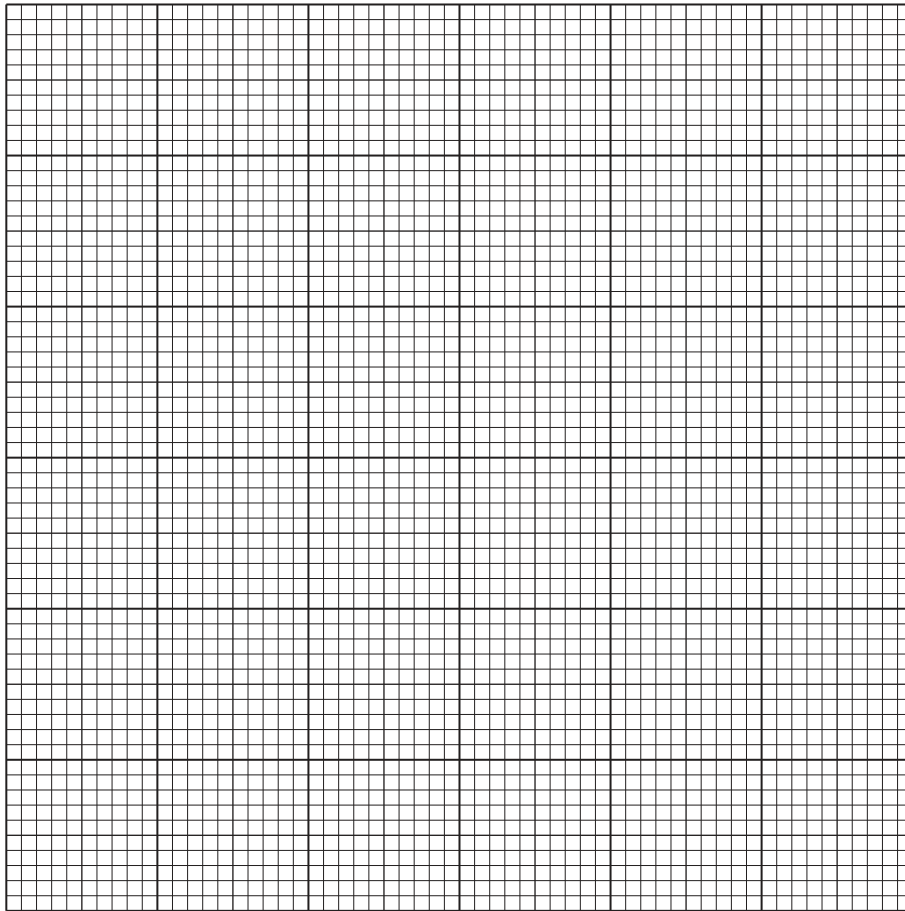

[4]

- (iii) Use this information to suggest the main food substance present in food **S1**.  
Give a reason for your answer.

.....  
.....  
.....  
.....

[2]

[Total : 21]

2 S2 is a seedling that has been growing in moist soil in the light.

(a) (i) Make a large, labelled drawing of the seedling.

[6]

(ii) Measure the length of your drawing. Draw a line to show where you made the measurement.

length of drawing .....

Measure the length of the seedling.

length of seedling .....

Calculate the magnification of your drawing.

Show your working.

Magnification = ..... [3]

(b) S3 is a seedling of the same species as S2 that has been allowed to germinate and grow in the dark.

(i) State two **visible** differences between S2 and S3.

1 .....

.....

2 .....

..... [2]

(ii) Suggest two reasons for these differences.

1 .....

.....

2 .....

..... [2]

(c) Suggest how you could carry out an investigation into the effect of gravity on the growth of the young root of germinating seeds.

.....

.....

.....

.....

.....

.....

.....

.....

.....

.....

.....

..... [6]

[Total : 19]

**BLANK PAGE**

---

Permission to reproduce items where third-party owned material protected by copyright is included has been sought and cleared where possible. Every reasonable effort has been made by the publisher (UCLES) to trace copyright holders, but if any items requiring clearance have unwittingly been included, the publisher will be pleased to make amends at the earliest possible opportunity.

University of Cambridge International Examinations is part of the University of Cambridge Local Examinations Syndicate (UCLES), which is itself a department of the University of Cambridge.